

PRICE PUMP CO.

CLOSE COUPLED CENTRIFUGAL
MOTOR PUMPS

TYPE SC

316 STAINLESS STEEL
Up to 160 GPM Up to 90 Feet

APPLICATIONS

O. E. M.—Scrubbers, filters, washers, plating equipment.

Industry—Deionized water, acids, alkali, food products.

Agriculture—Fertilizer, acids and other agricultural chemicals.

FEATURES

- All 316 stainless steel "wetted" metal parts.
- All castings are investment cast for accuracy and improved efficiency. (Except SC150 volute which is shell molded).
- Mechanical seal design. Type 21 Viton, carbon vs. ceramic single seal standard.
- Teflon Type 9 single seal optional. Other seal faces and elastomers available.
- Double Type 21 Viton, Neoprene or EPR seals optional.
- Single seal flush available.
- Standard NEMA 56C face motors (ball bearing) supplied in single phase or three phase. Drip-proof standard. T.E. available through 3 HP and X-P available through 2 HP.
- Equivalent models available in cast iron, cast-iron-bronze-fitted (CIBF) or all bronze. See Type EC and E100-B Bulletin #105.

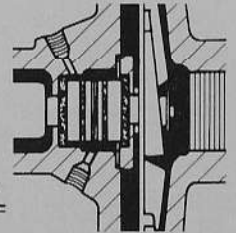
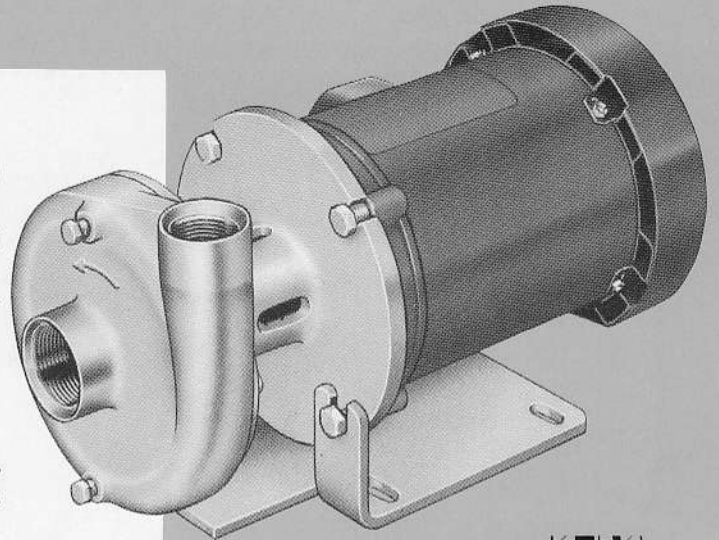

DOUBLE SEAL
OPTION

ALSO AVAILABLE AS:

FRAME MOUNTED
Type SC-FM
(see Bulletin #124)

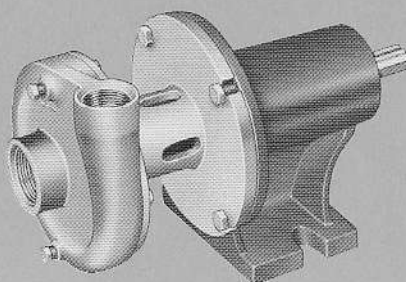

with AIR MOTOR DRIVE
(see Bulletin #127)

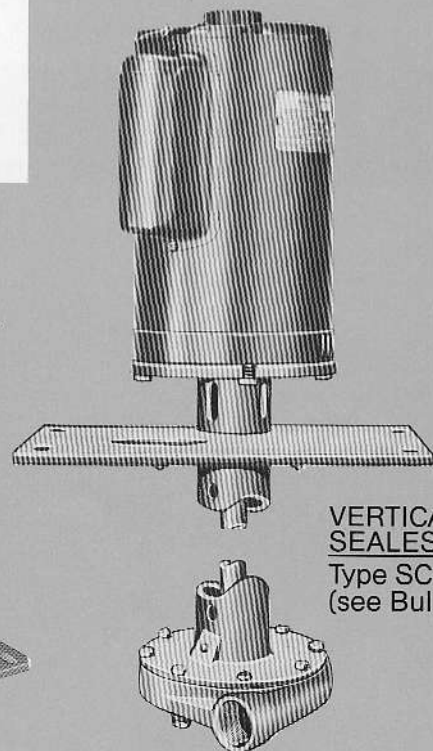
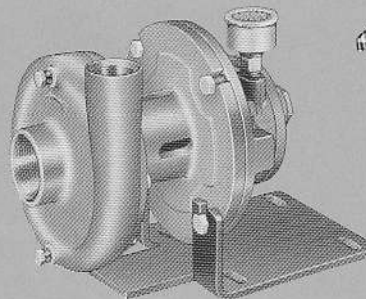

VERTICAL
SEALESS DESIGN
Type SC-V
(see Bulletin #115)

TYPE SC STAINLESS STEEL CENTRIFUGAL MOTOR PUMPS

PERFORMANCE CURVES

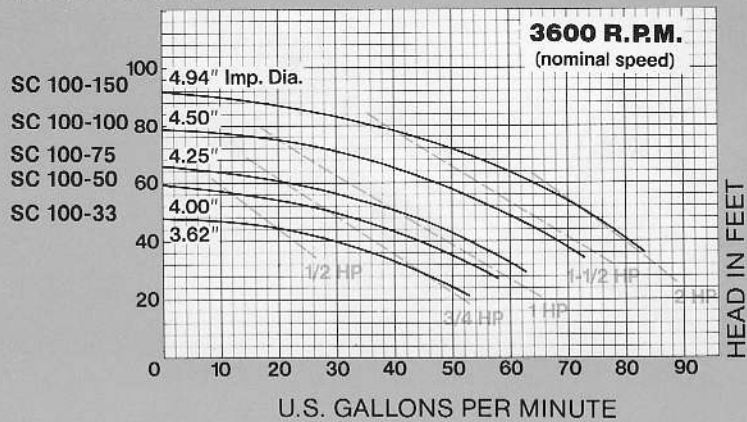
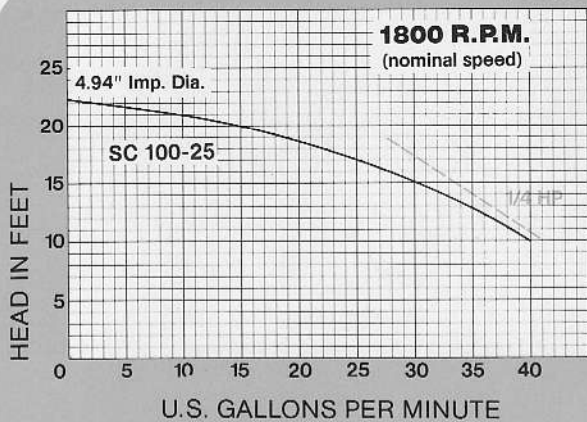

Note: Dotted lines show HP required on 1.0 SG liquid. Pumps with enclosed motors (except SC100-25 and SC150 models) will be supplied with the next size motor.

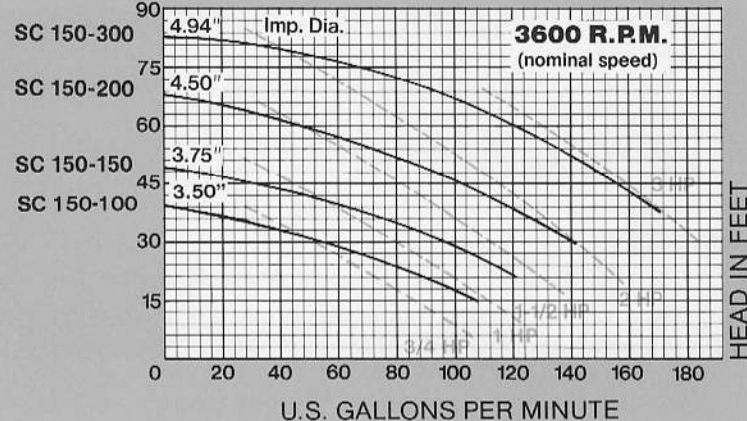
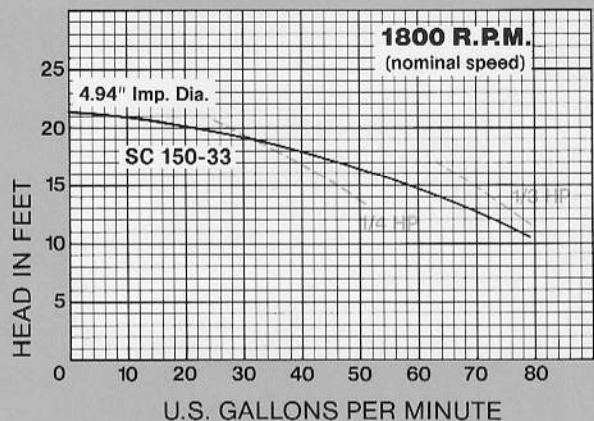

DIMENSIONS - in inches

AG Dimensions based on 1/60 - 115/230 V motors

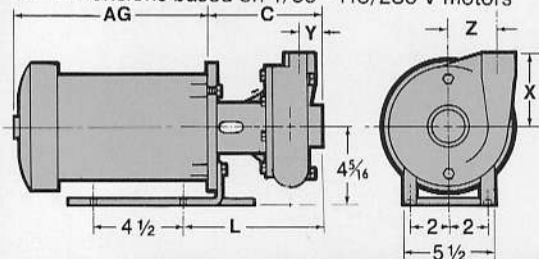

Model No.	Approx.		Disch.	Suct.	C	L	X	Y	Z
	AG	Ship Wght.							
SC100-25	7 3/4	34							
SC100-33	8 1/2	35							
SC100-50	8 3/4	36							
SC100-75	9 1/4	39	1	1 1/4	5 3/8	6 3/8	3 3/4	1 3/8	2 3/8
SC100-100	9 3/4	43							
SC100-150	10 1/2	49							
SC150-33	8 3/4	43	1 1/2	2	5 11/16	6 3/8	3 13/16	1 1/2	3 3/8
SC150-150	10 1/2	57							
SC150-200	11 1/4	62							
SC150-300	12 3/4	65							

PARTS LIST

	SC100		SC150	
	Single Seal	Double Seal	Single Seal	Double Seal
A. Impeller:				
Sizes:				
25	0248	0992		
33	0249	0993		
50	0250	0994		
75	0251	0995		
100	0252	0996		
150	0248	0992		
B. Volute	0247		0237	
C. Shaft	0255-2		0255-3	
D. Bracket:				
Single Seal			0972	
Double Seal			0972-1	
E. Seal with Seat:				
Viton T.21			0553	
Teflon T.9			1150	
DOUBLE SEAL				
Viton T.21 (2 rqd.)			0985	
Neoprene T.21 (2 rqd.)			0984	
E.P.R. T.21 (2 rqd.)			1023	
D.S. Seal Cover			0973	
D.S. Seal Cover Gasket			0974	
Seal Cover Bolts (3 rqd.)			0256	
F. Volute Bolts (8 rqd.)			0917	
G. Pipe Plugs (2 rqd.)			0559	
H. Impeller Locking Screw & Washer (not shown)			0256 & 0257	
J. Motor Bolts:				
2 ea. rqd.			0593	
2 ea. rqd.			0673	
K. Base			0199	
L. Gasket, Teflon			0507	
M. Slinger - 3/8"			0522	

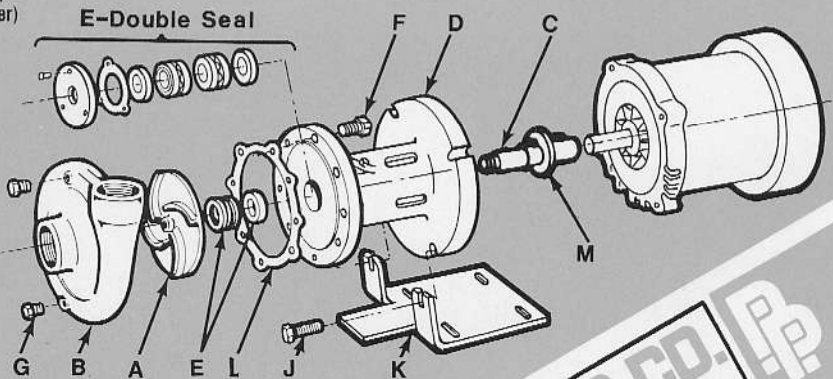

PRICE PUMP CO.
19672 - 8th Street East
P.O. Box Q
Sonoma, California 95476
Tel: (707) 938-8441
FAX (707) 938-0764